

AMENDED AND RESTATED
DESIGN AND LANDSCAPE
GUIDELINES
OF
DENVER CONNECTION WEST

Adopted by the Board of Directors of the Denver Connection West Metropolitan District
on April 25, 2017, revised May 28, 2019

TABLE OF CONTENTS

1 INTRODUCTION 4

1.1 Basis for Design and Landscape Guidelines..... 4

1.2 Definitions..... 4

1.3 Contents of Rules..... 4

1.4 Architectural Review Committee or Representative 4

1.5 ARC Contact Information..... 4

1.6 Effect of Declaration..... 4

1.7 Effect of Governmental and Other Regulations..... 4

1.8 Interference with Utilities 5

1.9 Goal of Guidelines 5

2 PROCEDURES FOR ARC APPROVAL 5

2.1 General..... 5

2.2 Drawings or Plans..... 5

2.3 Submission of Drawings and Plans..... 6

2.4 Action by ARC 7

2.5 Revisions and Additions to Approved Plans 7

2.6 Completion of Work 7

2.7 Requirements for Initial Installation of Backyard Landscaping 7

2.8 Inspection of Work 8

2.9 Notice of Non-Compliance..... 8

2.10 Correction of Non-Compliance..... 8

2.11 Amendment..... 8

2.12 Questions..... 8

3 SPECIFIC TYPES OF IMPROVEMENTS / SITE RESTRICTIONS..... 8

3.1 General..... 8

3.2 Accessory Buildings 9

3.3 Additions and Expansions..... 9

3.4 Address Numbers..... 10

3.5 Air Conditioning Equipment..... 10

3.6 Animals..... 10

3.7 Artificial Turf..... 10

3.8 Antennae/Satellite Dishes 10

3.9 Awnings 11

3.10 Backyard Sport Pads. 12

3.11 Balconies..... 12

3.12 Barbecue/Gas Grills 12

3.13 Basketball Backboards..... 12

3.14 Birdbaths 12

3.15 Birdhouses and Bird Feeders 12

3.16 Carports..... 13

3.17 Clothes Lines and Hangers 13

3.18 Cloth or Canvas Overhangs 13

3.19 Decks..... 13

3.20	Dog Houses	13
3.21	Dog Runs	14
3.22	Doors	14
3.23	Drainage	14
3.24	Driveways	14
3.25	Evaporative Coolers.....	14
3.26	Exterior Lighting.....	15
3.27	Fences	15
3.28	Fire Pits	16
3.29	Firewood Storage.....	16
3.30	Flags/Flagpoles	16
3.31	Gardens – Flower or Vegetable	17
3.32	Gazebos.....	17
3.33	Grading and Grade Changes	17
3.34	Greenhouses.....	17
3.35	Hanging of Clothes	17
3.36	Hot Tubs and Jacuzzis	17
3.37	Kennels	17
3.38	Landscaping.....	17
3.39	Leases.....	18
3.40	Lights and Lighting.....	18
3.41	Lights, Sounds and Odors	19
3.42	Nuisances	19
3.43	Ornaments/Art - Landscape/Yard.....	19
3.44	Overhangs/Sunshades/Awnings- Cloth or Canvas	19
3.45	Painting	19
3.46	Patio Covers.....	20
3.47	Patios – Enclosed.....	20
3.48	Patios – Open	20
3.49	Paving	20
3.50	Pipes.....	20
3.51	Play Structures and Sports Equipment.....	20
3.52	Playhouses.....	20
3.53	Poles.....	21
3.54	Ponds and Water Features.....	21
3.55	Pools.....	21
3.56	Radio Antennae.....	21
3.57	Radon Mitigation Systems.....	21
3.58	Roofing Materials	21
3.59	Rooftop Equipment.....	22
3.60	Satellite Dishes.....	22
3.61	Saunas	22
3.62	Screen Doors	22
3.63	Seasonal Decorations	22
3.64	Security Devices.	22
3.65	Sheds.....	22

3.66	Shutters – Exterior	22
3.67	Siding	22
3.68	Signs.....	23
3.69	Solar Energy Devices.....	23
3.70	Spas.....	23
3.71	Statues or Fountains.....	23
3.72	Storage Sheds.....	23
3.73	Sunshades.....	23
3.74	Swamp Coolers	24
3.75	Swing Sets.....	24
3.76	Television Antennae	24
3.77	Trash and Materials, Restrictions	24
3.78	Tree Houses	24
3.79	Units to be Maintained.....	24
3.80	Vehicular Parking, Storage and Repairs	24
3.81	Vanes.....	25
3.82	Vents	26
3.83	Walls	26
3.84	Walls, Retaining.....	26
3.85	Weather Vanes and Directionals.....	26
3.86	Wind Electric Generators.....	26
3.87	Windows Replacement	26
3.88	Windows: Tinting, Security Bars, Well Covers, etc.....	26
3.89	Xeriscape.....	26
EXHIBIT A PRIVACY FENCES		28
EXHIBIT B SECURITY DOORS.....		29
APPENDIX A ARCHITECTURAL REVIEW REQUEST FORM.....		33

1 **INTRODUCTION**

1.1 Basis for Design and Landscape Guidelines

These Design and Landscape Guidelines (the “**Guidelines**”) are intended to assist Owners living in the Denver Connection West community (the “**Community**”). Pursuant to the Declaration of Covenants, Conditions and Restrictions of Denver Connection West (“**Declaration**”), recorded at Reception No. 2017095170 in the City & County of Denver. The Denver Connection West Metropolitan District (“**District**”) is authorized to adopt Design and Landscape Guidelines for the Community.

1.2 Definitions

All capitalized words and phrases used in these Rules shall have the meaning provided in the Declaration unless otherwise defined herein.

1.3 Contents of Rules

In addition to the introductory material, these Guidelines contain (A) a summary of procedures for obtaining approval from the Architectural Review Committee (“ARC”) (see Section 2); and (B) a listing of specific types of improvements that Owners might wish to make with specific information as to each of these types of improvements (see Section 3).

1.4 Architectural Review Committee or Representative

The ARC consists of persons, representatives or a committee appointed by the Denver Connection West Metropolitan District Board of Directors to review requests for approval of architectural, landscaping improvements or site changes.

1.5 ARC Contact Information

The contact information of the ARC, persons, committee or representative authorized to administer the architectural review process is:

COMPANY	OFFICE	FAX	E-MAIL
SDMS	303-987-0835	303-987-2032	pripko@sdmsi.com

1.6 Effect of Declaration

The Declaration governs the Community. Each Owner should review and become familiar with the Declaration. Nothing in these Guidelines supersedes or alters the provisions or requirements of the Declaration and, if there is any conflict or inconsistency, the Declaration will control.

1.7 Effect of Governmental and Other Regulations

Use of property within the Community and any Improvements must comply with any applicable building codes and other governmental requirements and regulations. Owners are encouraged to contact the City and County of Denver for further information and requirements for Improvements they wish to make.

APPROVAL BY THE ARC DOES NOT CONSTITUTE ASSURANCE THAT IMPROVEMENTS COMPLY WITH APPLICABLE GOVERNMENTAL REQUIREMENTS OR REGULATIONS OR THAT A PERMIT OR APPROVALS ARE NOT ALSO REQUIRED FROM APPLICABLE GOVERNMENTAL BODIES.

1.8 Interference with Utilities

In making Improvements to property, Owners are responsible for locating all water, sewer, gas, electrical, cable television, or other utility lines or easements. Owners should not construct any Improvements over such easements without the consent of the utility involved, and Owners will be responsible for any damage to any utility lines. All underground utility lines and easements can be located by contacting:

**Utility Notification Center of Colorado
1-800-922-1987 or 811**

1.9 Goal of Guidelines

Compliance with these Guidelines and the provisions of the Declaration will help preserve the inherent architectural and aesthetic quality of the Community. It is the responsibility of the ARC to ensure that all proposed Improvements meet or exceed the requirements of these Guidelines and to promote the highest quality design for the neighborhood. It is important that Improvements to property be made in harmony with and not detrimental to the rest of the Community. A spirit of cooperation with the ARC and neighbors will go far in creating an optimum environment, which will benefit all Owners. By following these Guidelines and obtaining prior written approval for Improvements to property from the ARC, Owners will be protecting their financial investment and will help ensure that Improvements to property are compatible with standards established for the Community. If a question ever arises as to the correct interpretation of any terms, phrases or language contained in these Guidelines, the ARC's interpretation shall be final and binding.

2 PROCEDURES FOR ARC APPROVAL

2.1 General

The procedures set forth in this Article 2 are intended to clarify the terms, provisions and requirements of Article 2 of the Declaration. In the event of any conflict between these Guidelines and the Declaration, the terms of Article 2 in the Declaration shall control. As indicated in Section 3 of these Guidelines, there are some cases in which advance written approval of the ARC is not required if the Guidelines with respect to that specific type of Improvement are followed. In a few cases, as indicated in Section 3, a specific type of Improvement is not permitted under any circumstances. In all other cases, including Improvements not included in Section 3, advance, or prior written approval by the ARC is required before an Improvement to property is commenced.

2.2 Drawings or Plans

Owners are required to submit to the ARC a completed Architectural Review Request Form ("ARR"), which forms are available from the person or entity listed in Section 1.5, and complete plans and specifications, in duplicate, (said plans and specifications to show exterior design, height, materials, color, location of the structure or addition to the structure, plotted horizontally and vertically, location and size of driveways, general plan of landscaping, fencing, walls, windbreaks and grading plan, as well as such other materials and information as may be required) prior to commencement of work on

any Improvement to property. In most cases, the materials to be submitted will not have to be professionally prepared by an architect, a landscape architect, or draftsman, and a simple drawing with dimensions and description will be sufficient. In the case of major improvements, such as room additions, structural changes or accessory building construction, detailed plans and specifications, prepared by a licensed architect, may be required. Whether done by the Owner, or professionally, the following guidelines should be followed in preparing drawings or plans:

- A. The drawing or plan should be done to scale and shall depict the property lines of your Lot and the outside boundary lines of the home as located on the Lot. If you have a copy of an improvement survey of your Lot obtained when you purchased it, this survey would be an excellent base from which to start.
- B. Existing Improvements, in addition to your home, should be shown on the drawing or plan and identified or labeled. Such existing Improvements include driveways, walks, decks, trees, shrubs, fences, etc. The proposed Improvements should be shown on the plan and labeled. Either on the plan or on an attachment, there should be a brief description of the proposed Improvement, including the materials to be used and the colors. For Example: Redwood deck, ten (10) feet by twelve (12) feet with two inches by four inch (2"x4") decking and natural stain.
- C. The plan or drawing and other materials should include the name of the Owner, the address of the home, the lot, block and filing number of the Lot, and the e-mail address and telephone number where the Owner can be reached.
- D. The proposed Improvements must take into consideration the easements, building location restrictions and sight distance limitations at intersections.
- E. Owners should be aware that many Improvements require a permit from the City and County of Denver or other governmental entity. The ARC reserves the right to require a copy of such permit as a condition of its approval.
- F. In some instances, elevation drawings of the proposed Improvement will be required. The elevation drawings should indicate materials.
- G. Photographs of existing conditions and of proposed materials and colors are encouraged to be included, and are helpful to convey the intended design, but should not be used solely to describe the proposed changes.

2.3 Submission of Drawings and Plans

Two copies of the drawing or plans (minimum acceptable size 8.5" x 11") must be submitted to the ARC along with a completed ARR. Color photographs, brochures, paint swatches, etc. will help expedite the approval process. Specific dimensions and locations are required.

Any costs incurred by the ARC for review of submittals shall be borne by the Owner and shall be payable prior to final approval. Any reasonable engineering consultant fees or other fees incurred by the ARC in reviewing any submission will be assessed to the Owner requesting approval of the submission.

2.4 Action by ARC

The ARC will review plans submitted for approval. The ARC may require submission of additional information or material, and the request will be deemed denied until all required information and materials have been submitted. The ARC will act upon all requests in writing within forty-five (45) days after the complete submission of plans, specifications, and other materials and information as requested by the ARC. If the ARC fails to review and approve in writing (which may be with conditions and/or requirements) or disapprove, a request for architectural approval within forty-five (45) days after the complete submission of the plans, specifications, materials and other information with respect thereto, such request is deemed approved by the ARC.

2.5 Revisions and Additions to Approved Plans

Any revisions and/or additions to approved plans made by the Owner or as required by any governmental agency, must be re-submitted for approval by the ARC. The revised plans must follow the requirements as outlined above.

2.6 Completion of Work

After approval (which may be with conditions and/or requirements) of any proposed Improvement by the ARC, the proposed Improvement shall be completed and constructed as promptly and diligently as possible, and in complete conformity with all conditions and requirements of the approval. Failure to complete the proposed Improvement within one year from the date of the approval or such other date as may be set forth in the approval or as set forth in the Declaration (the "**Completion Deadline**"), shall constitute noncompliance; provided, however, that the ARC may grant extensions of time to individual Owners for completion of any proposed Improvements, either (a) at the time of initial approval of such Improvements, or (b) upon the request of any Owner, provided such request is delivered to the ARC in writing and the Owner is diligently prosecuting completion of the subject Improvements or other good cause exists at the time such request is made.

2.7 Requirements for Initial Installation of Backyard Landscaping

Within the time frames as hereinafter provided, subject to applicable "**force majeure**" delays as determined by the ARC, the Owner of each Unit (other than Developer or a Builder) shall install landscaping on all portion of the Unit which is not covered by a building or other Improvement, as well as on the tree lawn areas adjacent to such Unit, if applicable. The Owner of each Unit (other than Developer or a Builder) shall install landscaping on such Unit, and on adjacent tree lawn areas, within the time period set forth in the Guidelines or, if not set forth in the Guidelines, then: within one hundred (180) days after acquisition of such Unit by such Owner, if said acquisition occurs between April 1 and July 31; or, by the following July 31, if such acquisition does not occur between April 1 and July 31.

Landscaping plans must be submitted to the ARC for review and approval (which may be with conditions and/or requirements), and such approval must be obtained prior to the installation of landscaping. Each Owner shall maintain all landscaping on such Owner's Unit, and on adjacent tree lawn areas, in a neat and attractive condition, including periodic and horticulturally correct pruning, removal of weeds and debris, and replacement of landscaping.

2.8 Inspection of Work

The ARC, or its duly authorized representative, shall have the right to inspect any Improvement at any time, including prior to or after completion, in order to determine whether or not the proposed Improvement is being completed or has been completed in compliance with the approval granted pursuant to this Section.

2.9 Notice of Non-Compliance

If, as a result of inspections or otherwise, the ARC determines that any Improvement has been done without obtaining all required approvals (which may be with conditions and/or requirements), or was not done in substantial compliance with the approval that was granted, or has not been completed by the Completion Deadline, subject to any extensions of time granted pursuant to Section 2.6 hereof, then the ARC shall notify the District, and the District shall then notify the applicant in writing of the non-compliance (the "Notice of Non-Compliance"). The Notice of Non-Compliance shall specify the particulars of the non-compliance.

2.10 Correction of Non-Compliance

If the ARC determines that non-compliance exists, the Person responsible for such non-compliance shall remedy or remove the same within not more than forty-five (45) days from the date of receipt of the Notice of Non-Compliance. If such Person does not comply with the ruling within such period, the ARC shall notify the District, and the District may, at its option and if allowed by applicable law, record a notice of non-compliance against the Lot on which the non-compliance exists, may impose fines, penalties and interest, may remove the non-complying Improvement, or may otherwise remedy the non-compliance in accordance with the Declaration and applicable law. The Person responsible for such non-compliance shall reimburse the District, upon demand, for all costs and expenses, as well as anticipated costs and expenses, with respect thereto.

2.11 Amendment

These Guidelines may at any time, from time to time, be added to, deleted from, repealed, amended, and modified, reenacted, or otherwise changed by the ARC, with the approval of the Person authorized to appoint the ARC, as changing conditions and/or priorities dictate.

2.12 Questions

If you have any questions about the foregoing procedures, feel free to call the ARC at the phone number and address listed in the Section 1.5 of these Rules.

3 SPECIFIC TYPES OF IMPROVEMENTS / SITE RESTRICTIONS

3.1 General

The following is a listing, in alphabetical order, of a wide variety of specific types of Improvements which Owners typically consider installing, with pertinent information as to each. Unless otherwise specifically stated, drawings or plans for a proposed Improvement must be submitted to the ARC and written approval of the ARC obtained before the Improvements are made. In some cases, where it is specifically so noted, an Owner may proceed with the Improvements without advance approval if the Owner follows the stated guideline. In some cases, where specifically stated, some types of

Improvements are prohibited. ARC review and approval is required on any external items not be listed below.

A. Variances

Approval of any proposed plans by the granting of a variance from compliance with any of the provisions of these Guidelines is at the sole discretion of the ARC when circumstances such as topography, natural obstructions, hardship, aesthetic or environmental considerations may require.

B. No Unsightliness

No unsightly conditions can exist, including but not limited to, structures, facilities, equipment, and objects. Any equipment, including but not limited to snow removal equipment, garden or maintenance equipment, must be enclosed within a structure when not in use.

C. Waivers; No Precedent

The approval or consent of the ARC to any application for approval shall not be deemed to constitute a waiver of any right to withhold or deny approval or consent as to any application or other matters whatsoever, as to which approval or consent may subsequently or additionally be required. Nor shall any such approval or consent be deemed to constitute a precedent in any other matter.

D. Liability

The ARC and the members thereof shall not be liable in damages to any person submitting requests for approval or to any approval, or failure to approve or disapprove in regard to any matter within its jurisdiction. The ARC shall not bear any responsibility for ensuring structural integrity or soundness of approved construction or modifications, or for ensuring compliance with building codes and other governmental requirements. The ARC will not make any investigation into title, ownership, easements, rights-of-way, or other rights appurtenant to property with respect to architectural requests and shall not be liable for any disputes relating to the same.

3.2 Accessory Buildings

No storage sheds or accessory buildings are permitted on Lots; approval will not be granted.

A playhouse or play structure shall not be considered an accessory building. However, existing setbacks required of the home must be observed when placing playhouses. A copy of the home's plot plan filed with the location of the proposed accessory building is required with the ARR.

3.3 Additions and Expansions

Approval is required. Additions or expansions must be constructed of wood, Masonite, glass, brick, stone, or other material as used in construction of the exterior of the home. The design must be the same or generally recognized as a complimentary architectural style and meet all design guidelines as may be applicable. Colors must be the same as that of the residence. Patios may not be more than twenty five percent (25%) of the entire rear yard of the Lot unless otherwise approved by the ARC.

3.4 Address Numbers

Approval is required to replace, alter or relocate existing address numbers, unless the address numbers are replaced using the same style, color and type of number currently on the residence.

3.5 Air Conditioning Equipment

Approval is required for all air conditioning equipment including evaporative coolers (swamp coolers) and attic ventilators installed after the initial construction.

Approval is not required for replacement of existing air conditioning equipment with like equipment located in the same location as the equipment being replaced.

No heating, air conditioning, air movement (e.g. swamp coolers) or refrigeration equipment shall be placed or installed on rooftops, or extended from windows. Ground mounted or exterior wall air conditioning equipment installed in the side yard must be installed in a manner so as to minimize visibility from the street and minimize any noise to adjacent property Owners.

3.6 Animals

No animals, livestock (pigs, cattle, horses, goats, lamas, etc.), birds, poultry, reptiles or insects of any kind may be raised, bred, kept or boarded in or on the Units except as permitted by, and in compliance with, the ordinances of the City, as applicable, and any Guidelines and/or the Rules and Regulations that do not conflict with such the ordinances of the City, as applicable. An Owner's right to keep household pets is coupled with the responsibility for collecting and properly disposing of any animal waste and to pay for all damage caused by such pets.

3.7 Artificial Turf

See Section 3.89, Xeriscape

3.8 Antennae/Satellite Dishes

A. General Provisions

“Permitted Antennas” are defined as (a) an antenna which is less than one meter in diameter and is used to receive direct broadcast satellite service, including direct-to-home satellite services, or is used to receive or transmit fixed wireless signals via satellite; (b) an antenna which is less than one meter in diameter and is used to receive video programming services via multipoint distribution services, including multichannel multipoint distribution services, instruction television fixed services, and local multipoint distribution services or is used to receive or transmit fixed wireless signals other than via satellite; (c) an antenna which is designed to receive broadcast television broadcast signals; or (d) other antennas which are expressly permitted under applicable federal statutes or regulations. In the event a Permitted Antenna is no longer expressly permitted under applicable federal statutes or regulations, such antenna will no longer be a Permitted Antenna for purposes of this Section. Installation of Permitted Antennas shall not require the approval of the ARC.

- A. All Permitted Antennas shall be installed with emphasis on being as unobtrusive as possible to the Community. To the extent that reception is not substantially degraded or costs unreasonably increased, all Permitted Antennas shall be

screened from view from any street and nearby Lots to the maximum extent possible, and placement shall be made in the following order of preference:

- (1) Inside the structure of the house, not visible from the street
 - (2) Rear yard or side yard, behind and below the fence line
 - (3) Rear yard or side yard, mounted on the house, in the least visible location below roofline
 - (4) Side yard in front of wing fence, screened by and integrated into landscaping
 - (5) Back rooftop
 - (6) Front yard screened by and integrated into landscaping
- B.** If more than one (1) location on the Lot allows for adequate reception without imposing unreasonable expense or delay, the order of preference described above shall be used, and the least visible site shall be selected.
- C.** Permitted Antennas shall not encroach upon common areas or any other Owner's property.

B. Installation of Antennae/Satellite Dishes

- A.** All installations must comply with all applicable building codes and other governmental regulations, and must be secured so they do not jeopardize the safety of residents or cause damage to adjacent properties. Any installation must strictly comply with FCC guidelines.
- B.** All Permitted Antennas shall be no larger, nor installed more visibly, than is necessary for reception of an acceptable signal.
- C.** Owners are responsible for all costs associated with the Permitted Antenna, including but not limited to costs to install, replace, repair, maintain, relocate, or remove the Permitted Antenna.
- D.** All cabling must be run internally when feasible, must be securely attached, and must be as inconspicuous as possible. Permitted Antennas, masts and any visible wiring may be required to be painted to match the color of the structure to which they are attached. The Owner should check with the installer/vendor for the appropriate type of paint.
- E.** All other antennas, not addressed above, are prohibited.

3.9 Awnings

Approval is required and Owners must comply with all requirements of the City and County of Denver. Awnings should be an integral part of the house or patio design. The color shall be complimentary to the exterior of the residence.

See Section 3.39, Overhangs/Sunshades/Awnings – Cloth or Canvas.

3.10 Backyard Sport Pads.

Approval is required. Backyard, concrete pads for “sport” type courts must be approved by the ARC. The ARC will consider backyard sport courts based on pad size, Lot size and proximity to other Lots. Sport equipment installed or stored on or around the pad must be maintained at all times in a neat and clean manner.

3.11 Balconies

See Section 3.17, Decks.

3.12 Barbecue/Gas Grills

Approval is required for all permanent or built-in structures. Approval is not required for portable units. All barbecue grills, smokers, etc. must be stored in the rear yard or within an enclosed structure, not visible from the front of the home.

3.13 Basketball Backboards

Approval is not required, subject to the following limitations. No basketball backboards shall be attached to the garage. Only portable basketball backboards shall be allowed if the following guidelines are met:

- A. Portable units cannot be placed in the public rights of way, streets, sidewalks or street lawns.
- B. Location must be in the driveway, at least half of the length of the driveway away from the street, or in the side or rear yard.
- C. Portable basketball backboards may be left out when not in use only if the backboard, hoop, and net are in good repair. Portable basketball backboards that are not in good repair, including the hoop and net, must be stored out of sight when not in use and may not be left out for more than 24 hours.
- D. Permanent garage or pole mounted basketball hoops are not permitted.

3.14 Birdbaths

Approval is not required, subject to the following limitations. Placement in front or side yard is not allowed. Birdbaths are only permitted in the rear yard.

See Section 3.66, Statues or Fountains.

3.15 Birdhouses and Bird Feeders

Approval is not required, subject to the following limitations. If installed in the rear yard and the size is limited to one foot by two feet, no approval is required. No more than three of each of a birdhouse or bird feeder shall be installed on any Lot. Birdhouses or bird feeders may be mounted on a pole, provided the pole shall not exceed five (5) feet in height.

3.16 Carports

Approval will not be granted.

3.17 Clothes Lines and Hangers

Approval is not required, subject to the following limitations. Clotheslines may only be placed in the rear yard. Fixed clotheslines and hangers are not permitted. Temporary drying structures will be permitted so long as such structures are used solely in the rear yard of a lot and are immediately removed from sight after each use. Retractable clotheslines with permanent fixtures require approval.

3.18 Cloth or Canvas Overhangs

See Section 3.39, Overhangs/Sunshades/Awnings – Cloth or Canvas.

3.19 Decks

Approval is required. The deck must be harmonious (in configuration, detail, material and color) with the architecture of the house. Modifications or additions to Builder installed decks must incorporate the same materials, colors and detailing as the Builder's or approved existing deck. TREX or similar engineered composite wood type products are the preferred material for construction. Plastic, PVC or similar materials are prohibited.

The appropriate governmental permits may also require.

The deck should be located so as not to create an unreasonable level of noise for adjacent property Owners.

Changes in grade or drainage pattern must not adversely affect adjoining properties and shall comply with drainage change requirements of the Declaration.

Upper-level decks shall be attached directly to the house. Only ground level decks may be approved as freestanding decks. Decks shall not extend beyond the Lot boundaries into any common area. Depending on Lot location and orientation, decks should not project beyond the side walls of the house. The side walls of the house are defined as the major (structural) side walls and do not include bay windows, chimney enclosures, porches or other such projections. In certain situations, stairs and some portions of the deck may extend up to 4' beyond the side walls.

A solid trim board shall be provided on any open side of the deck to conceal the joists and cut ends of the decking. Underdeck screening should be compatible with the architecture of the house and deck. Any lattice must be properly framed and recessed.

Railings and other features such as privacy screens for attached housing must match the approved Builder design.

3.20 Dog Houses

Approval is required. Dog houses are restricted to ten (10) square feet and must be located in a fenced back yard or dog run. Dog houses must be installed at ground level, and must not be visible above the fence. Dog houses must also match the colors and materials of the exterior of the home. Limit of one dog house per Lot.

3.21 Dog Runs

Approval is required. Dog runs must be located in the rear or side yard, abutting the home and substantially screened from view by planting fast-growing or mature trees or shrubs. Dog runs will be limited to two hundred (200) square feet, unless a variance is granted by the ARC. Dog run fences should be left natural in color and sealed to prevent weathering. The ARC may adopt approved heights, stains and configurations for fencing. Covers (ex: tarps, sheets, blankets, etc.) on dog runs are not allowed.

3.22 Doors

Approval is not required for an already existing main entrance door to a home or an accessory building if the material matches or is similar to existing doors on the house and if the color is generally accepted as a complimentary color to that of existing doors on the house. Complementary colors would be the body, trim or accent colors of the house or white (for storm/screen doors).

- A. Storm Doors. Approval is not required for storm doors as long as the door is complimentary with the color scheme of the home. Owners wishing to utilize a different color must first obtain approval.
- B. Security Doors and Windows. Approval is not required for the installation of the pre-approved security doors as specified in Exhibit B. All other security or security-type doors and windows must be approved prior to installation.

3.23 Drainage

The Declaration requires that there be no interference with the established drainage pattern over any property. The established drainage pattern means the drainage pattern which exists at the time final grading of a Lot by the Declarant or a Builder is completed. When installing your landscaping, it is very important to ensure that water drains away from the foundation of the house and that the flow patterns prevent water from flowing under or against the house foundation, walkways, sidewalks, and driveways into the street. The ARC may require a report from a drainage engineer as part of landscaping or improvement plan approval. Landscaping and all drainage from downspouts off the house should conform to the established drainage pattern. Sump pump drainage should be vented a reasonable distance from the property line, on the Owner's property, to allow for absorption. Adverse effects to adjacent properties, including District lands, sidewalks and streets, will not be tolerated.

3.24 Driveways

Approval is required for any changes or alterations to driveways. This includes construction of a pull-off area to the side of the driveway and/or concrete driveway extensions. Only clear sealant may be used on the driveway (no colors) and Owners will be required to maintain the driveways against oil spills, spalling/peeling/etc.

3.25 Evaporative Coolers

Approval is required. No rooftop or window mount installations are allowed. See Section 3.5, Air Conditioning Equipment.

3.26 Exterior Lighting

See Section 3.37, Lights and Lighting.

3.27 Fences

A. General Statement

Fences constructed by the Developer or Builder on the Owner's lot along or abutting property lines, arterial streets, collector streets, and local streets may not be removed, replaced, painted/stained a different color or altered, including, adding a gate, without approval of the ARC.

Most of the fences constructed by the Developer or Builder are located on the Owners property (within the lot lines) and are to be maintained (repaired, replaced if necessary and re-stained as necessary) by the Owner of the property the fence is located on. Owners' shall repair or recondition fences located on their property at their own expense and as necessary and or required by the ARC and/or Denver Connection West Metropolitan District.

B. [Reserved]

C. Fence Designs

All fences not installed by the Developer and/or Builder that are to be installed by an Owner require approval of the ARC and shall comply with the exact fence specifications attached as Exhibit A or other design guidelines as may be adopted by the ARC. Double fencing of property lines shall not be permitted.

Please see Exhibit A for example of approved fencing per the ARC.

D. Stain Color/Maintenance

All Fences installed by Owners' are required to be stained the color - "SEAGULL GRAY" GS224 "SOLID GRAIN STAIN" MANUFACTURED BY DIAMOND VOGEL.

All fences constructed by Owners' on Lots shall be maintained in good condition and repair by the Owner. Fences installed by Owners' on their lot will be owned and maintained by the Owner. **Fences installed by the Developer and/or Builder are located on Owners lots will be owned and maintained by the Owner of that lot the fence is located on.** In the event any fences installed are installed on common area by the Developer and/or Builder will be owned and maintained by the Denver Connection West Metropolitan District.

E. [Reserved]

F. Prior Approved Fencing

Replacement of any existing fencing must comply with the attached Exhibit A or the then current guidelines or ARC adopted standards related to fencing.

G. Pet Fencing

Pet fencing may include any invisible fence on or within the perimeter boundary of an Owner's lot. **Wire mesh fencing is not permitted nor necessary as the approved fencing style for the community is a solid fence.** See Exhibit A for example of approved fencing to be used in the community.

See Section 3.18, Dog Houses and Section 3.19, Dog Runs.

3.28 Fire Pits

Approval is required. The only fire pits that are permitted are those powered by propane or natural gas and they must be more than 10 feet from any structure, or combustible materials.

3.29 Firewood Storage

All firewood must be located in the side or rear yard, must be neatly stacked, shall not be visible from any street or the ground level of any other Lot, and must not be located so as to block established drainage patterns.

3.30 Flags/Flagpoles

Approval is required for any freestanding flagpole.

Approval is not required for flagpoles mounted to the front of the residence provided that the flags displayed thereon (if other than an American Flag) are temporary in nature and are only displayed on holidays or in celebration of specific events. They must not be placed earlier than forty-five (45) days prior to the start of the particular holiday/event or celebration and must be removed no later than thirty (30) days following the particular holiday/event or celebration. Under no circumstance may the height of the flagpole exceed the height of the roofline of the residence. Flag size cannot exceed five (5) feet in length and three (3) feet in width.

American Flags: Owners shall be permitted to display an American flag in accordance with the Federal Flag Code (P.L.,94-344, 90stat.810;4U.S.C. SECS 4 to 10) and as follows:

- A.** The flag shall be no larger than three (3) feet by five (5) feet.
- B.** The flag may be displayed in a window or from a flagpole projecting horizontally from a location on the front of the dwelling.
- C.** Flags and/or flagpoles shall be replaced as necessary in order to prevent wear and tear.
- D.** Flags may not be illuminated without prior written approval of the ARC. Any request for lighting must detail the type and location of lighting. Lighting shall be placed so as not to disturb Owners of neighboring Lots.

An Owner or resident may display a service flag bearing a star denoting the Owner's or resident's or his family member's active or reserve U.S. military service during a time of war or armed conflict. The flag may be displayed on the inside of a window or door of the home on the Lot. The flag may not be larger than nine (9) inches by sixteen (16) inches.

3.31 Gardens – Flower or Vegetable

Approval is not required for flower or vegetable gardens that do not exceed one hundred fifty (150) total square feet. All flower gardens must be weeded, cared for and maintained. Vegetable gardens shall be located in the rear or side yard and should not be placed nor will be allowed within 5 feet of the foundation of the home.

3.32 Gazebos

Approval is required. A gazebo must be an integral part of the rear yard landscape plan and must be similar in material and design to the residence. The color must be generally accepted as a complementary color to the exterior of the residence.

3.33 Grading and Grade Changes

Owners are not permitted to alter the approved grading design of the lot so as to alter the drainage pattern of the lot. See Section 3.21, Drainage

3.34 Greenhouses

Approval is required. Generally, greenhouses are discouraged due to the extensive maintenance required. Approval will be based upon but not limited to general aesthetics, quality and permanence of materials used. Adequate screening will be required.

3.35 Hanging of Clothes

See Section 3.15, Clothes Lines and Hangers.

3.36 Hot Tubs and Jacuzzis

Approval is required. Hot tubs and Jacuzzis must be an integral part of the deck or patio area and of the rear yard landscaping, and be installed in such a way that it is not immediately visible to adjacent property Owners and that it does not create an unreasonable level of noise for adjacent property Owners. In some instances, additional plant material around the hot tub may be required for screening. Non-vegetative screening materials should match or complement the house or deck structure. Prefabricated hot tub enclosures will be evaluated on a case-by-case basis, and may require additional plant material screening.

3.37 Kennels

Approval will not be granted. Breeding or maintaining animals for a commercial purpose is prohibited.

Also see Section 3.19, Dog Runs.

3.38 Landscaping

Within the time frames as hereinafter provided, subject to applicable "**force majeure**" delays as determined by the ARC, the Owner of each Unit (other than Developer or a Builder) shall install landscaping on all portion of the Unit which is not covered by a building or other Improvement, as well as on the tree lawn areas adjacent to such Unit. The Owner of each Unit (other than Developer or a Builder) shall install landscaping on such Unit, and on adjacent tree lawn areas, within one hundred (180) days after acquisition of such Unit by such Owner, if said acquisition occurs between April 1

and July 31; or, by the following July 31, if such acquisition does not occur between April 1 and July 31.

Approval is required. All Owners must comply with any applicable landscaping requirements of the County and the City. The plot plan of the residence and yard must be provided at a measurable scale. All organic materials (plants, shrubs, trees, etc.), building materials (stone, wood, edging, etc.), must be clearly labeled in detail.

The ARC may adopt approved landscape requirements and standards, and all new landscape installations and improvements must meet said requirements. Owners are responsible for compliance with all applicable laws.

Each Owner shall maintain all landscaping on such Owner's Unit, and on adjacent tree lawn areas, in a neat and attractive condition, including periodic and horticulturally correct pruning, removal of weeds and debris, and replacement of landscaping.

3.39 Leases

The term "**lease**," as used herein, includes any agreement for the leasing or rental of a Unit, or any portion thereof, and shall specifically include month to month rentals and subleases, but not leases having a term of less than 30 days except if the Owner of a Unit enters into a lease-back of the Unit in connection with such Owner's sale of the Unit that will permit such Owner to continue occupying the Owner's Unit after the closing of the sale of the Unit. Any Owner shall have the right to lease his Unit, or any portion thereof, as long as all leases provide that the lease, and lessee's occupancy of the leased premises, are subject in all respects to the Governing Documents; and that any failure by the lessee to comply with any of the Governing Documents, in any respect, constitutes a default under the lease.

3.40 Lights and Lighting

Approval is not required for replacing existing lighting, including coach lights, with the same lighting style and color as originally installed.

Approval is required to modify builder installed lighting fixtures or to add exterior lighting.

Approval is required to install motion detector spotlights, spotlights, floodlights or ballasted fixtures (sodium, mercury, multi-vapor, fluorescent, metal halide, etc.).

- A.** Considerations will include, but may not be limited to, the visibility, style and location of the fixture.
- B.** Exterior lighting for security and/or other uses must be directed at the ground and house, whereby the light cone stays within the property boundaries and the light source does not cause glare to other properties (bullet type light fixtures are recommended).
- C.** Ground lighting along walks must be maintained in a working and sightly manner. Low- voltage or solar powered ground lighting fixtures which are typically affixed by stakes or similar posts are to be maintained in good aesthetic repair, be functional, not be a tripping or other physical hazard along pedestrian pathways, and remain generally vertical in their presentation.

- D.** Holiday lighting and decorations do not require approval. It is required that they not be installed more than thirty (30) days prior to the holiday. They shall be removed within thirty (30) days following the holiday.

3.41 Lights, Sounds and Odors

No light shall be emitted which is unreasonably bright or causes unreasonable glare; no sound shall be emitted from any Unit which is unreasonably loud or annoying; and no odor shall be permitted from any Unit which is noxious or interferes with the reasonable and peaceful enjoyment or possession of another Unit by occupant thereof.

3.42 Nuisances

No nuisance is permitted which is visible within or otherwise affects any portion of the Property, nor any use, activity or practice which interferes with the peaceful enjoyment or possession and proper use of any Unit, or any portion thereof, by its residents. Construction activity performed by the Developer, approved Builders', the Metropolitan District or any entity approved by the ACR performing activities related to development of the property and/or Units, Lot or other structures are exempt from this section.

3.43 Ornaments/Art - Landscape/Yard

Approval is not required for yard ornaments which are installed in the rear yard and which are of a height less than three (3) feet.

Up to three (3) small (less than 12 inches in height) front yard ornaments may be installed in the front yard without approval, as long as the ornament is installed at ground level and the color and design integrate into the landscape.

Approval is required for any other yard ornaments.

See Section 3.66, Statues or Fountains.

3.44 Overhangs/Sunshades/Awnings- Cloth or Canvas

Approval is required. An overhang should be an integral part of the house or patio design. The color must be the same as, or generally recognized as, a complementary color to the exterior of the residence. A swatch of material to be used must be provided with the review submittal.

See Section 3.41, Patio Covers.

3.45 Painting

Approval is not required to repaint a house if the color and/or color combinations are identical to the original manufacturer color established on the home and/or accessory improvement and installed by the Builder. Any changes to the original color scheme installed by the Builder must be submitted for approval and must conform to the general color scheme of the Community.

3.46 Patio Covers

Approval is required. Patio covers must be constructed of material consistent with the home and be similar or generally recognized as complementary in color to the colors on the house. Freestanding patio covers may be permitted as well as extensions of the roof.

3.47 Patios – Enclosed

See Section 3.3, Additions and Expansions.

3.48 Patios – Open

Approval is required. Open patios must be an integral part of the landscape plan and must be located so as not to create an unreasonable level of noise for adjacent property Owners. In some instances, additional plant material around the patio may be required for screening or integration into the landscape design. The patio and materials must be similar or generally accepted as a complementary color and design to the residence.

See Section 3.17, Decks.

3.49 Paving

Approval is required, regardless of whether for walks, driveways, patio areas or other purposes, and regardless of whether concrete, asphalt, brick, flagstones, stepping stones, pre-cast patterned, or exposed aggregate concrete pavers are used as the paving material.

See Section 3.11, Driveways.

3.50 Pipes

Approval is required for all exterior pipes, conduits and equipment. Adequate screening may also be required.

3.51 Play Structures and Sports Equipment

Approval is required. Consideration will be given to adjacent properties (a minimum five (5) foot setback from the property line, is required for trampolines, swing sets, fort structures, etc.) so as not to create an undue disturbance. In some instances, additional plant material around the equipment may be required for screening. Wood structures must be constructed of pressure treated or other weather resistant materials. All play equipment must be maintained in a good and sightly manner. The use of multi-colored permanent cloth/canvas tarps will be considered on a case by case basis and consideration will be given to the colors requested so as to not be unsightly to adjacent residences. Height of any play structure or sports equipment may not exceed twelve (12) feet.

Toys, bikes and other sports equipment must be stored out of view when not in use.

3.52 Playhouses

Approval is not required if a structure is less than twenty-four (24) square feet and less than six (6) feet high, from highest point to the ground.

Approval is required for structures greater than twenty-four (24) square feet and/or greater than six (6) feet high, from the highest point to the ground.

See Section 3.2, Accessory Buildings.

3.53 Poles

See Section 3.28, Flags/Flagpoles.

3.54 Ponds and Water Features

Approval is required. Considerations by the ARC will include, but not be limited to, the following criteria:

- A. Must be integrated into landscape scheme.
- B. Setback shall be a minimum of five (5) feet from all property lines.
- C. Must not affect existing drainage on the lot or off the property.
- D. Must be maintained at all times.

3.55 Pools

Approval is required. Pools must be placed in the rear yard and be an integral part of the deck or patio area. They should be located in such a way that they are not immediately visible to adjacent property Owners (i.e. screened with plant material). Above ground pools and temporary pools are prohibited. One (1) wading pool, if less than eighteen (18) inches high and eight (8) feet in diameter, per Lot, is permitted on a temporary basis without prior approval, if placed in the rear yard.

See Section 3.34, Hot Tubs and Jacuzzis.

3.56 Radio Antennae

See Section 3.6, Antennae/Satellite Dishes.

3.57 Radon Mitigation Systems

Approval is required. Equipment must be painted a color similar or generally accepted as complimentary to the exterior of the house. All equipment shall be installed so as to minimize its visibility.

3.58 Roofing Materials

Approval is required for all roofing materials other than those originally used by the Builder. All buildings constructed on a Lot should be roofed with the same or greater quality and type of roofing material as originally used by the Builder.

Approval is not required for repairs to an existing roof with the same building material and color that exist on the building.

3.59 Rooftop Equipment

Approval is required but generally will not be allowed. Equipment must be painted a color similar or generally accepted as complimentary to the roofing material of the house. All rooftop equipment shall be installed so as to minimize its visibility.

See Section 3.64, Solar Energy Devices.

3.60 Satellite Dishes

See Section 3.6, Antennae/Satellite Dishes.

3.61 Saunas

See Section 3.2, Accessory Buildings.

3.62 Screen Doors

See Section 3.20, Doors.

3.63 Seasonal Decorations

Approval is not required if installed on a lot within forty-five (45) days of a holiday, provided that an Owner is keeping with the Community standards, and provided that the decorations are removed within thirty (30) days of the holiday.

See Section 3.37, Lights and Lighting.

3.64 Security Devices.

Approval is not required. Security devices, including cameras and alarms, must be selected, located and installed so as to be an integral part of the house and not distract from the home's architecture and appearance. Cameras and housing sirens, speaker boxes, conduits and related exterior elements should be unobtrusive and inconspicuous. Such devices should be located where not readily visible and should be a color that blends with or matches the surface to which it is attached.

3.65 Sheds

See Section 3.2, Accessory Buildings.

3.66 Shutters – Exterior

Approval is required and generally will not be approved if the shutters are not of the same design, material and/or color as originally installed by the Builder. New proposed shutters should be appropriate for the architectural style of the home and be of the appropriate proportion to the windows they frame. Shutters should be the same color as the “accent” color of the home (typically the same as the front door or other accent details).

3.67 Siding

Approval is required.

3.68 Signs

Approval is not required for one (1) temporary sign advertising property for sale or lease or one (1) open house sign, which shall be no larger than five (5) square feet and which are conservative in color and style; one (1) yard/garage sale signs which is no larger than 36" x 48"; and/or burglar alarm notification signs, ground staked or window mounted which are no larger than 8" x 8" Such signs may be installed in the front yard or on the back yard fence of the Lot.

Political signs (defined as signs that carry a message intended to influence the outcome of an election, including supporting or opposing the election of a candidate, the recall of a public official, or the passage of a ballot issue) may be displayed no earlier than 45 days prior to an election and must be removed within 7 days of the election. No more than one (1) sign per political office of ballot measure may be maintained on an individual lot. Political signs shall not exceed 36" by 48" in size.

Approval is required for all other signs. No lighted signs will be permitted unless utilized by the Developer and/or a Builder.

3.69 Solar Energy Devices

Approval is required in order to review aesthetic conditions. Photovoltaic (PV) Solar panels must lay flat on the roof, meet all applicable safety, building codes and electrical requirements, including solar panels for thermal systems (solar water heaters). The ARC is allowed to request changes as long as they don't significantly increase the cost or decrease the efficiency of the proposed device and panels. Please also see Colorado Law C.R.S. 38-30-168, which governs the review and the Owner's installation of such devices.

3.70 Spas

See Section 3.34, Hot Tubs and Jacuzzis.

3.71 Statues or Fountains

Approval is not required if statues or fountains are installed in the rear yard and are not greater than four (4) feet in height from the highest point, including any pedestal.

Approval is required if the statue or fountain is proposed for the front yard. Statue or fountain location in the front yard should be located close to the main entrance of the house.

See Section 3.12, Birdbaths and Section 3.38, Ornaments/Art – Landscape/Yard

3.72 Storage Sheds

Approval will not be given.

See Section 3.60, Sheds and Section 3.2, Accessory Buildings.

3.73 Sunshades

See Section 3.39, Overhangs/Awnings – Cloth or Canvas and Section 3.41, Patio Covers.

3.74 Swamp Coolers

See Section 3.5, Air Conditioning Equipment, Section 3.23, Evaporative Coolers, and Section 3.54, Rooftop Equipment.

3.75 Swing Sets

See Section 3.46, Play Structures and Sports Equipment.

3.76 Television Antennae

See Section 3.6, Antennae/Satellite Dishes.

3.77 Trash and Materials, Restrictions

No refuse, garbage, trash, lumber, grass, shrubs or tree clippings, plant waste, metal, bulk materials, scrap or debris of any kind shall be kept, stored, or allowed to accumulate on a Lot or a street, unless placed in a suitable covered container or trash bin that is suitably located solely for the purpose of trash or recycling pickup. Further, no trash or materials shall be permitted, to accumulate in such a manner as to be visible from any Unit. All equipment for the storage or disposal of such materials shall be kept in a clean and sanitary condition. No trash cans, trash bins or other trash or recycling receptacles shall be maintained in an exposed or unsightly manner. Finally, trash removal and recycling services may be subscribed to by the Metropolitan District on behalf of the residents of all or any portion of the Property and, if so, the Board of the Metropolitan District may determine the scope, frequency, and all other matters, with regard to such trash removal and recycling services; and the Owners shall pay their proportionate share of such trash removal and recycling services, as determined by the Board of the Metropolitan District. This section shall not be construed to prevent composting.

Trash cans/bags can be out from 6pm the night before collection day to noon the day after collection day. When not out for collection, trash cans/bags must be stored out of view.

3.78 Tree Houses

Approval will not be granted. Tree houses are not permitted.

3.79 Units to be Maintained

Each Lot (including adjacent tree lawn area(s)) and the Improvements thereon shall at all times be maintained, repaired and replaced in a good, clean and slightly condition by the Owners of such Lot. Any concrete foundation components and concrete post-tension slab that is installed as part of the construction of any Units on the Property or any geogrid extending underground from any retaining wall on or adjacent to a Lot shall not be cut, drilled, removed or modified by any Owner unless such work is performed in accordance with plans prepared by a licensed structural engineer and any requirements of the ARC. Maintenance includes but is not limited to paint, roofing, windows and landscape.

3.80 Vehicular Parking, Storage and Repairs

- A. Mobile homes, recreational vehicles, trailers (either with or without wheels), campers, camper trailers, boats and other watercraft, recreational vehicles and boat trailers may only be parked in enclosed garages or specific areas, if any, which may

be designated by the ARC, but this restriction shall not prevent the parking of such vehicles as a temporary expedient for loading, delivery or emergency. No parking is allowed on any landscaped area. Stored vehicles and vehicles which are inoperable or do not have current operating licenses are not permitted on the Property except within enclosed garages. For purposes of this Section, the ARC may determine whether a vehicle is considered "stored". For example, a vehicle may be considered to be "stored" if it is up on blocks or covered with a tarp and remains on blocks or so covered for seventy-two (72) consecutive hours without the prior approval (which may be with conditions and/or requirements) of the ARC.

- B.** No activity, including maintenance, repair, rebuilding, dismantling, repainting or servicing of any kind of vehicles, trailers or boats, may be performed or conducted in the Property unless it is done within completely enclosed structure(s) which screen the sight and sound of the activity from the street and from adjoining property. Any Owner or other Person undertaking any such activities shall be solely responsible for, and assumes all risks of: such activities, including adoption and utilization of any and all necessary safety measures, precautions and ventilation. However, the foregoing restrictions do not prevent washing and polishing of any motor vehicle, boat, trailer, motor-driven cycle, or other vehicle on a Unit, together with those activities normally incident and necessary to such washing and polishing.
- C.** In the event the ARC or the Board of the Metropolitan District determines that a vehicle is parked or stored in violation of subsections 3.7.1 or 3.7.2 hereof, then a written notice describing said vehicle shall be personally delivered to the owner thereof (if such owner can be reasonably ascertained) or shall be conspicuously placed upon the vehicle (if the owner thereof cannot be reasonably ascertained), and if the vehicle is not removed within a reasonable time thereafter, as determined by the ARC or the Board of the Metropolitan District, then the ARC or the Board of the Metropolitan District. may have the vehicle removed at the sole expense of the owner thereof.
- D.** Garages shall not be converted for habitable living space or for storage which prevents the parking of automobiles therein. No Owner or occupant of a Unit and no invitee of an Owner or occupant shall park or permit to be parked any vehicle upon any street or driveway or elsewhere in such a manner as to block, impair or impede access to and from another Owner's garage.
- E.** DEVELOPER, EACH BUILDER, THE METROPOLITAN DISTRICT, AND THE ARC, HEREBY DISCLAIM ANY AND ALL OBLIGATIONS REGARDING, RELATING TO OR ARISING OUT OF, THE PERFORMANCE OF ANY MAINTENANCE, SERVICING, REBUILDING, REPAIR, DISMANTLING, OR REPAINTING OF ANY TYPE OF VEHICLE, BOAT, TRAILER, MACHINE OR DEVICE OF ANY KIND, BY ANY OWNER OR OTHER PERSON.

3.81 Vanes

See Section 3.77, Weather Vanes and Directionals.

3.82 Vents

See Section 3.54, Rooftop Equipment.

3.83 Walls

See Section 3.25, Fences and Section 3.76, Walls, Retaining.

3.84 Walls, Retaining

Approval is required except that an Owner may replace a builder-installed wall with like material.

New or old creosote treated timber railroad ties are prohibited.

3.85 Weather Vanes and Directionals

Approval is required.

3.86 Wind Electric Generators

Approval is required. In addition to ARC approval, windmills and any other type of fixture, which fall under the criteria of a wind generator, or are used to generate power etc., must meet the requirement of the C.R.S. 40-2-124 and any applicable regulations of the Colorado Public Utilities Commission.

3.87 Windows Replacement

Approval is not required when replacing with identical windows if installed correctly according to manufacturer's instructions. If changing styles, considerations will include, but may not be limited to, size, color, existing and proposed window style and style of home.

3.88 Windows: Tinting, Security Bars, Well Covers, etc.

Approval is not required for window well covers that are manufactured with metal or plexiglass. All others will require ARC approval.

Approval is required for any visible window tinting. Highly reflective and/or dark tinting is considered too commercial for residential applications and is not permitted.

Approval is required for security bars and generally will not be approved.

3.89 Xeriscape

Approval is required. Using drought tolerant plantings and other water conservation methods of landscaping is encouraged; however, the design must be approved. Xeriscape uses much less water than typical suburban residential landscape, but it does not mean that large areas of river rock or mulch will be allowed in place of green, growing plant material. Artificial turf is permitted with the following guidelines:

- A. The synthetic turf must be natural in appearance and integrated into the overall landscape design in a natural looking manner, so as not to appear as a sports field and it shall not be installed directly adjacent to the property line.

- B. The general appearance of the synthetic turf must be designed and installed in such a manner as to effectively simulate the appearance of a well-maintained lawn.
- C. The synthetic turf uniformity must be maintained for all areas.
- D. No synthetic turf shall be installed or approved in the front yard and/or the tree lawn area.
- E. Turf must have a minimum of an 8-year product warranty and the warranty shall not be limited to the amount of usage, lawn elevation, nor the type of footwear that can be worn.
- F. Installation must assure adequate drainage, must have an adequate subgrade, be properly secure
- G. be free of ripples or showing of seams, have finished edges, and be securely attached to prevent lateral movement.

REMAINDER OF PAGE INTENTIONALLY LEFT BLANK.

EXHIBIT A PRIVACY FENCES

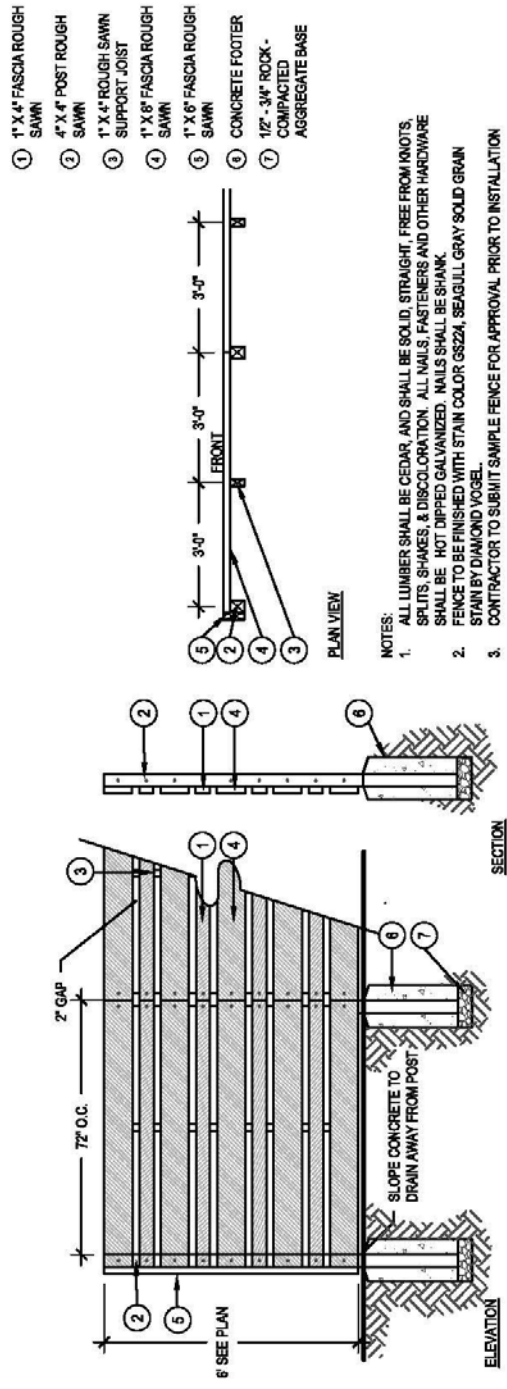

○ EXHIBIT A: RESIDENTIAL PRIVACY FENCE
AVION AT DENVER CONNECTION

SCALE: 1/4" = 1'-0"

**EXHIBIT B
FENCE STAIN**

Product Name:

Grain Stain Exterior Solid Latex Stain (Product Code: BT1504)

Color Name:

GS224SO

Seagull SO

Product Details:

Product is available in 1 gallon cans or 5 gallon pails.

Price per gallon is below:

(Subject to change)

1 gallon cans: \$31.99 per gallon

5 gallon pails: \$31.69 per gallon

Store Location and Information:

(Subject to change)

Diamond Vogel Paint

4500 East 48th Ave

Denver, CO 80216

(303) 333-3117

Hours:

Monday – Friday, 7am – 5pm

Saturday, 8am – 12pm



Grain Stain

Exterior Solid Latex Stain

Product Data Sheet

PRODUCT DESCRIPTION

Grain Stain Solid Latex Stain is a high quality exterior 100% acrylic stain that dries to a durable, blister resistant, breather type finish. Its excellent fade resistance allows colors to remain beautiful for years.

TYPICAL USES

Formulated for use as a finish coat on a variety of residential and commercial exterior surfaces. These include previously stained or painted exterior wood, hardboard, cement board and masonry surfaces. Suitable for use on siding, trim and fences. Grain Stain Solid Latex Stain is self priming on bare exterior wood surfaces. Two coats are recommended for optimum performance and uniformity.

BASES & COLORS (tintable with ACS colorant)

BT-1504 Light Base	0-6 oz/gal
BT-1503 Dark Base	4-10 oz/gal
BT-9502 Black Base	0-6 oz/gal

PHYSICAL PROPERTIES (BT-1504)

Resin Type	100% Acrylic
Clean-up Solvent	Water
Finish	0-5 @ 85°
Solids by Weight	49 %
Solids by Volume	38 %

Recommended Dry Film Thickness per Coat	1.5-2 mils
Wet Film to Achieve DFT	4-5 mils
Theoretical Coverage @ 1 mil	610 ft ² /gallon
Practical Coverage at Recommended DFT ¹	305-407 ft ² /gallon

Dry Times ² @ 70° F (21° C) and 50% R.H.	Touch ½-2 hours Recoat 2-4 hours
---	-------------------------------------

VOCs (Range from 93-128 depending on color and base)	126 grams/liter
---	-----------------

¹ Spread rates are estimates based on products volume solids and make no allowance for material loss during application. Actual spread rates may vary dependent on applicator experience, surface porosity and texture.

² Dry times may vary depending upon temperature, humidity and degree of air movement.

SPECIFICATIONS

Exterior Wood/Plywood

- 2 cts Grain Stain Exterior Solid Latex Stain or
- 1 ct Grain Stain Exterior Solid Oil Stain
- 2 cts Grain Stain Exterior Solid Latex Stain

Block

Smooth

- 2 cts Grain Stain Exterior Solid Latex Stain Or
- 1 ct Any BU-Series Acrylic Latex Primer
- 2 cts Grain Stain Exterior Solid Latex Stain

Porous

- 1 ct Any BF-Series Exterior Block Filler
- 2 cts Grain Stain Exterior Solid Latex Stain

Poured Concrete

- 1 ct Any BU-Series Acrylic Latex Primer
- 2 cts Grain Stain Exterior Solid Latex Stain

Cement Siding

Pre-primed

- 2 cts Grain Stain Exterior Solid Latex Stain

Unprimed

- 1 ct Any BU-Series Acrylic Latex Primer
- 2 cts Grain Stain Exterior Solid Latex Stain

This product meets or exceeds Master Painters Institute (MPI) #16 approval standards.

This data sheet provides general recommendations and not intended to limit the use of this product. Test areas are always recommended to confirm results. For more detailed recommendations, please contact your local Diamond Vogel Sales Representative.

SURFACE PREPARATION

All surfaces must be cured, clean, sound, dry and free of all dirt, dust, efflorescence, wax, oil, grease, chalk and any other contamination that would interfere with new coating adhesion. **Bare surfaces must be properly prepared prior to application of this product.**

Wood Surfaces

Patch nail holes, cracks and imperfections with exterior spackling compound. Sand and wipe clean. Woods subject to tannin bleeding should be primed with a stain blocking primer (BU-Series Sure Grip or AU-Series Alkyd Primer).

Masonry Surfaces- Poured Concrete, Concrete Block

New concrete and mortar should cure for a *minimum* of 30 days at 72° F (22° C) prior to coating application. Level all surface projections and mortar spatters by stoning. Rake mortar joints clean and remove all soluble salts.

Cement Board Be sure surface is clean and free of all contaminants.

Previously Painted Surfaces

- Power or hand washing is recommended to remove contamination. If oil or grease is present, use of a cleaner/degreaser is required. All cleaning residue must be completely rinsed from the surface. Allow to dry.
- Remove all loose coatings and corrosion by scraping, sanding or other abrading method. Dull glossy, slick and/or non-porous surfaces with sandpaper.
- Patch and fill areas as needed. Spot prime bare areas with appropriate primer.

Mildew

Remove by using a solution of one (1) part household bleach and three (3) parts water. Apply to mildewed area and scrub. Allow solution to remain on the surface for 3 to 5 minutes then rinse completely and allow to dry before coating application. Do not add ammonia to the bleach/water solution.

APPLICATION

- Stir material prior to application. Internix tinted containers to ensure color uniformity of all material.
- Equipment must be clean prior to start. Flush airless lines with clean water.
- Apply by brush, roller or spray. A good quality synthetic brush will make application easier. Select a roller cover suited for the texture of the surface to be coated. Airless tip sizes of .015 to .017 are recommended.
- Apply the product in full even coats and maintain a wet edge. Allow the product to dry between coats.
- Do not thin

ENVIRONMENTAL VARIABLES

Protect product from freezing prior to and during application. Minimum surface and air temperature required for application is 50° F (10° C) and at least 5° F (3° C) above the dew point. Curing is affected by temperature, humidity and air movement. The minimums must be maintained for at least eight (8) hours in order to achieve proper film formation. Application at elevated temperatures, wind conditions, and/or low humidity may require special application procedures to achieve proper film formation.

CLEAN-UP

Clean up spills immediately with soap and warm water. Clean hands and tools immediately after use with soap and warm water. After cleaning, flush spray equipment with mineral spirits to prevent rusting of the equipment.

CAUTIONS

For exterior use only

Do not apply below 50° F

Not intended for use on floors

Do not take internally

Use with adequate ventilation

KEEP OUT OF REACH OF CHILDREN

***WARNING!** If you scrape, sand, or remove old paint, you may release lead dust. LEAD IS TOXIC. EXPOSURE TO LEAD DUST CAN CAUSE SERIOUS ILLNESS, SUCH AS BRAIN DAMAGE, ESPECIALLY IN CHILDREN. PREGNANT WOMEN SHOULD ALSO AVOID EXPOSURE. Wear a NIOSH-approved respirator to control lead exposure. Clean up carefully with a HEPA vacuum and wet mop. Before you start, find out how to protect yourself and your family by contacting the National Lead Information Hotline at 1-800-424-LEAD or log on to www.epa.gov/lead.

Limited Warranty

The technical data and suggestions for use contained in this document are true and correct to the best of our knowledge at the date of issuance. The statements of this document do not constitute a warranty, expressed or implied, as to the performance of these products. Since Diamond Vogel does not control the application of its products, or the condition of the surfaces to which they are applied, Diamond Vogel's liability will under no circumstances exceed replacement of the product.

**EXHIBIT B
SECURITY DOORS**



White Surface Mount ClearGuard Security Door with Meshtec Screen



La Entrada White Surface Mount Outswin Steel Security Door with Perforated Metal Screen



Arcada White Surface Mount Outswing Steel Security Door with Expanded Metal Screen

**APPENDIX A
ARCHITECTURAL REVIEW REQUEST FORM**

Denver Connection West Metropolitan District
SDMS, Inc.
141 Union Blvd, Ste 150
Lakewood, CO 80228

FOR OFFICE USE ONLY
Date Received: _____
Crucial Date: _____
Date Sent to ARC: _____
Response Received: _____

NAME: _____

ADDRESS: _____

PHONE(S): _____

E-MAIL: _____

My request involves the following type(s) of improvement(s):

- | | | |
|--|---|---------------------------------------|
| <input type="checkbox"/> Landscaping | <input type="checkbox"/> Drive/Walk Addition | <input type="checkbox"/> Fencing |
| <input type="checkbox"/> Deck/Patio Slab | <input type="checkbox"/> Patio Cover | <input type="checkbox"/> Other: _____ |
| <input type="checkbox"/> Roofing | <input type="checkbox"/> Painting | |
| <input type="checkbox"/> Painting | <input type="checkbox"/> Basketball Backboard | |

Please describe proposed improvements in the area below or on a separate sheet.

Include two copies of your plot plans, and describe improvements showing in detail what you intend to accomplish (see Article 2 of the Rules and Regulations of Denver Connection West). Be sure to show existing conditions as well as your proposed improvements and any applicable required screening (see the Rules and Regulations for requirement details for your specific proposed Improvement).

<p>I understand that I must receive approval from the ARC in order to proceed with installation of Improvements if Improvements vary from the Rules and Regulations or, are not specifically exempt. I understand that I may not alter the drainage on my lot. I understand that the ARC is not responsible for the safety of Improvements, whether structural or otherwise, or conformance with building codes or other governmental laws or regulations, and that I may be required to obtain a building permit to complete the proposed Improvements. The ARC and the members thereof, as well as the District, the Board of Directors, or any representative of the ARC, shall not be liable for any loss, damage or injury arising out of or in any way connected with the performance of the ARC for any action, failure to act, approval, disapproval, or failure to approve or disapprove submittals, if such action was in good faith or without malice. All work authorized by the ARC shall be completed within the time limits established specified below, but if not specified, not later than one year after the approval was granted. I further understand that following the completion of my approved Improvement the ARC reserves to right to inspect the Improvement at any time in order to determine whether the proposed Improvement has been completed and/or has been completed in compliance with this Architectural Review Request.</p> <p>Date: _____ Homeowner's Signature: _____</p>
--

ARC Action:

- Approved as submitted
- Approved subject to the following requirements:

- Disapproved for the following reasons:

All work to be completed no later than: _____

Date: _____ Signature: _____